

**IN THE UNITED STATES DISTRICT COURT
NORTHERN DISTRICT OF ILLINOIS
EASTERN DIVISION**

PLANNED PARENTHOOD CHICAGO)
AREA, an Illinois non-profit Corporation, and)
GEMINI OFFICE DEVELOPMENT LLC,)
an Illinois limited liability company,)

Plaintiffs,)

v.)

CITY OF AURORA, ILLINOIS)

Defendant.)

No. 07 C 5181

Judge Norgle
Magistrate Brown

SUPPLEMENTAL DECLARATION OF STEVE TROMBLEY

I, Steve Trombley, hereby declare as follows:

1. I have personal knowledge of the facts set forth in the Declaration and could competently testify to them if called as a witness.
2. I am the President and CEO of Planned Parenthood Chicago Area ("PPCA").
3. I make this declaration in support of PPCA and Gemini Office Development LLC's ("Gemini") Motion for Preliminary Injunction.
4. This declaration supplements my declaration of September 12, 2007 already filed in this action.
5. Among the services Planned Parenthood will provide to both men and women at the 3051 E. New York Street facility are the following:
 - Annual gynecological exams;
 - Cancer screening for cervical, breast, and other cancers;
 - Examinations and counseling about birth control and family planning, including education about abstinence;
 - Prescribing and dispensing contraceptive drugs and devices;

- Screening and treatment for sexually transmitted infections;
- Screening and treatment for vaginal and urinary tract infections;
- Confidential HIV testing and counseling;
- Immunizations;
- Pap tests, as well as colposcopy and cryotherapy for abnormal Pap results; and
- Medical and surgical abortions.

6. Planned Parenthood provides these services on an “as needed basis” to its patients, regardless of means. For many people, then, this facility offers the only affordable gynecological, contraceptive or reproductive medical care within a reasonable distance.

7. Less than 10 percent of the services which Planned Parenthood provides relate to abortions.

8. On July 27, 2007, the Chicago Tribune published a front page article describing the Aurora clinic and Planned Parenthood’s role. **{A copy of this article is attached to the initial Trombley Affidavit as Exhibit 4}.**

9. In response to this article, opponents of abortion staged a candle light vigil at the outpatient facility on August 9, 2007. **{A copy of the Aurora Beacon article describing this event is attached hereto as Exhibit 1 to this Declaration.}**

10. Representatives of Planned Parenthood had conversations with officials of Aurora as early as February 2007. These conversations are supported by contemporaneous email and telephone records. **{A copy of the emails and telephone records of PPCA documenting these discussions is attached hereto as Exhibit 2}.**

11. Further, the bond financing which Planned Parenthood obtained through the Illinois Finance Authority required certain public disclosures. In and around May 2007, therefore, the Chicago SunTimes published public notices describing the relationship between

Planned Parenthood and Gemini, and a description of the Aurora medical facility. **{A copy of the SunTimes bond notice is attached hereto as Exhibit 3.}**

12. Finally, the architectural drawings that Gemini submitted to Aurora, contained unusual security features: bullet resistant glass in the reception area, bullet resistant doors and bullet resistant drywall. These security measures were necessary protection given the violence that has occurred at many abortion facilities, but also were early signals to Aurora. **{A copy of portions of the architectural drawings submitted to the City of Aurora is attached hereto as Exhibit 4.}**

13. On August 28, Aurora named Richard Martens, a former chair of the ABA Section of Municipal Law, as the attorney conducting the “independent review” of Planned Parenthood’s applications. **{A copy of the Aurora Beacon article describing the hiring of Mr. Martens is attached hereto as Exhibit 5.}**

14. On August 31, Aurora terminated Mr. Martens in response to complaints from City Council members. **{A copy of the Aurora Beacon article describing these events is attached hereto as Exhibit 6.}**

15. Aurora then named Phillip Luetkehans as the new “independent” council. However, questions soon arose about Mr. Luetkehans political contributions and his ability to conduct an “independent review.” **{A copy of the Aurora Beacon article describing these events is attached hereto as Exhibit 7.}**

16. Aurora then designated Kane County State's Attorney John Barsanti, as the new counsel to oversee the "independent review." **{A copy of the Aurora Beacon article describing these events is attached hereto as Exhibit 8}.**

17. I received two emails from Melissa Ernst attaching communications she received from Alderman Chris Beykirch, a member of the Aurora City Council representing Ward 8. **{Copies of the September 17 and September 18 emails are attached hereto as Exhibit 9}.**

18. On September 18, 2007, I received an email from Kelli Haley attaching correspondence she provided to the Aurora City Council. **{A copy of this email is attached hereto as Exhibit 10.}**

Further affiant sayeth not.



Steve Trombley

Dated this 19th day of September, 2007

Subscribed and sworn to before me this
19th day of September, 2007.

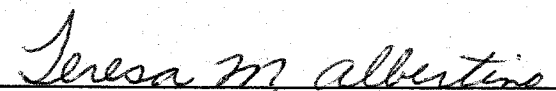

Notary Public

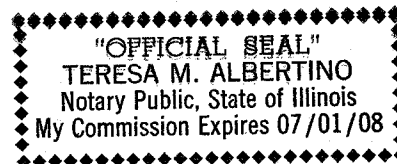

EXHIBIT 1

[Back to regular view](#) [Print this page](#)

Anti-abortion group to launch 40-day vigil in Aurora

August 9, 2007

By Kristen Zambo Staff Writer

AURORA — Anti-abortion demonstrators today will launch a 40-day vigil against a Planned Parenthood women's health center opening next month on Aurora's far East Side.

Motorists along Oakhurst Drive near the Dominick's grocery will be greeted, starting at 8 a.m., by demonstrators praying, reading Bible passages and holding signs about the medical center and against abortions. Planned Parenthood/Chicago Area staff plan to open a full-service health center on 3.24 acres at 240 N. Oakhurst Drive, in the DuPage County section of Aurora.

"We're pro-life and we want to let them know we're very upset with this," the Rev. Hugh Fullmer, pastor at Our Lady of Mercy Church in Aurora, said Wednesday. "It's not wanted in our community. That's why we're doing it."

The health center is scheduled to open Sept. 18. Abortion services are expected to be available at the approximately 22,000-square-foot office.

"I hope they bring lots of water with them because it's hot," said Steve Trombley, president and CEO of Planned Parenthood/Chicago Area.

The vigil will last from 8 a.m. to 11 p.m. today. For the remaining 39 days until the center opens, two- to three-person shifts will man the vigil in front of the health center 24 hours a day, Our Lady of Mercy parishioner Jane Fonner said.

"We feel that since the Planned Parenthood clinic probably will open ... we are going to pray just peacefully. It's just to ask for God's grace and mercy for the unborn," said Fonner, the mother of two adopted daughters.

The medical center will provide an array of women's health-care services, such as gynecological exams, birth control counseling and prescriptions and cervical cancer screening. An estimated 10 percent of the medical care there will involve abortions.

"It isn't going to have an impact on our opening whatsoever," Trombley said of the vigils. "The building is done. People need these services."

Demonstrations hosted in other communities haven't stopped patients from seeking medical services, nor shuttered any Planned Parenthood offices, he added.

Aurora Police Lt. Brian Olsen said no extra patrols are scheduled because of the protests.

"We'll only respond there if we're called," Olsen said. "Hopefully it's nice and quiet."

Members of the Pro-Life Action League have scheduled a meeting about the health center for 7 p.m. Aug. 16 at the Prisco Community Center, 150 W. Illinois Ave., Aurora. A planned Aug. 22 demonstration at the center has been rescheduled to Aug. 25.

kzambo@scn1.com

EXHIBIT 2

> -----Original Message-----

> From: Trombley, Steve

> Sent: Wednesday, February 21, 2007 9:53 AM

> To: Fischman, Tracy; Novak, Becky; Huyck, Teri;

> Petronis, Dainius

> Subject: Re: Bill Wyatt

>

> He was on the phone so I left him a message with my

> cell phone number. I

> didn't make the earlier flight so hopefully he will

> call back while I am

> sitting here.

>

> Steve

>

>

>

> -----Original Message-----

> From: Fischman, Tracy <tracyf@ppca.org>

> To: Novak, Becky <beckyn@ppca.org>; Trombley, Steve

> <Stevet@ppca.org>;

> Huyck, Teri <Teri@ppca.org>; Petronis, Dainius

> <dainiusp@ppca.org>

> Sent: Tue Feb 20 15:58:46 2007

> Subject: RE: Bill Wyatt

>

> Agreed. Let's go with Bill.

>

>

>

> Tracy Fischman, Vice President for Public Policy

>

> Planned Parenthood/Chicago Area

>

> 18 South Michigan Ave., 6th Floor

>

> Chicago, IL 60603

>

> Ph: 312.592.6833

>

> Fax: 312.592.6801

>

> www.plannedparenthoodaction.org

> <<http://www.plannedparenthoodaction.org>>

>

>

>

>

>

>

> From: Novak, Becky

> Sent: Tuesday, February 20, 2007 3:40 PM

> To: Fischman, Tracy; Trombley, Steve; Huyck, Teri;

> Petronis, Dainius

> Subject: RE: Bill Wyatt

>

>

>

> I can't find a cell number, but a friend has his

> home number. I think

> that might be a bit too much....

>

>

>

> _____

>

> From: Fischman, Tracy

> Sent: Tuesday, February 20, 2007 2:49 PM

> To: Novak, Becky; Trombley, Steve; Huyck, Teri;

> Petronis, Dainius

> Subject: RE: Bill Wyatt

>

>

>

> That does help - Steve, you were right that it might

> just make sense to

> call Bill directly.

>

>

>

> Tracy Fischman, Vice President for Public Policy

>

> Planned Parenthood/Chicago Area

>

> 18 South Michigan Ave., 6th Floor

>

> Chicago, IL 60603

>

> Ph: 312.592.6833

>

> Fax: 312.592.6801

>

> www.plannedparenthoodaction.org

> <<http://www.plannedparenthoodaction.org>>

>

>

>

>

> _____

>

> From: Novak, Becky

> Sent: Tuesday, February 20, 2007 2:37 PM

> To: Fischman, Tracy; Trombley, Steve; Huyck, Teri;

> Petronis, Dainius

> Subject: RE: Bill Wyatt

>

>

>

> I don't know. I am still trying to get his cell so

> when I get a return

> call I can ask. All I know is that this guy is a

> pretty nice guy and

> straightforward. He gets along well with the

> Mayor....don't know if

> that helps.

>

>

>

> _____

>

> From: Fischman, Tracy
> Sent: Tuesday, February 20, 2007 2:33 PM
> To: Novak, Becky; Trombley, Steve; Huyck, Teri;
> Petronis, Dainius
> Subject: RE: Bill Wyatt
>
>
>
> So do we know if he works for the mayor or for the
> city (and related to
> this - is he a political appointee or a civil
> servant who's been around
> awhile)?
>
>
>
> Tracy Fischman, Vice President for Public Policy
>
> Planned Parenthood/Chicago Area
>
> 18 South Michigan Ave., 6th Floor
>
> Chicago, IL 60603
>
> Ph: 312.592.6833
>
> Fax: 312.592.6801
>
> www.plannedparenthoodaction.org
> <<http://www.plannedparenthoodaction.org>>

>

>

>

>

>

>

> From: Novak, Becky

> Sent: Tuesday, February 20, 2007 2:29 PM

> To: Trombley, Steve; Huyck, Teri; Petronis, Dainius;

> Fischman, Tracy

> Subject: Bill Wyatt

>

>

>

> His official title is the Director of Community

> Development for the City

> of Aurora

>

> His phone number is (630) 844-3627

>

>

>

> Rebecca Novak

>

> Director, Field Operations

>

> Planned Parenthood/Chicago Area

>

> 18 S. Michigan Avenue, 6th Floor

>

> Chicago, IL 60603

>

> P: (312) 592-6861

>

> F: (312) 592-6801

>

> www.plannedparenthoodaction.org

>

>

>

>

>

>

>

> NOTE: Confidential Information - This transmission
> and any files, which may accompany the transmission,
> contain information belonging to Planned
> Parenthood/Chicago Area which is confidential and/or
> legally privileged. The information is intended only
> for the use of the individual or entity named above.
> If you are not the intended recipient, you are
> hereby notified that any disclosure, copying,
> distribution or the taking of any action in reliance
> on the contents of this information is strictly
> prohibited and illegal. If you have received this
> transmission in error, please immediately notify us
> by telephone at (312) 592-6815 to arrange for the
> return of the transmission and any accompanying
> files.

>



mjkasper60@aol.com
09/18/2007 09:32 AM

To jburden@hinshawlaw.com
cc
bcc
Subject Fwd: What's the address of Kank?

-----Original Message-----

From: Steve Trombley <stevetrombley@yahoo.com>
To: mjkasper60@aol.com
Sent: Mon, 17 Sep 2007 9:31 am
Subject: Fwd: FW: What's the address of Kank?

>

> Email #1

>

> -----Original Message-----

> From: Novak, Becky

> Sent: Thursday, February 22, 2007 12:17 PM

> To: Huyck, Teri; Trombley, Steve

> Cc: Fischman, Tracy

> Subject: RE: What's the address of Kank?

>

> Just got off the phone with Bill Wyatt in which he

> informed me that the

> address we gave him was already owned by someone

> else. I explained

> about the letter of intent and now "it all makes

> sense" so we're all

> good, he already checked on the permits for Gemini

> and everything is all

> set (obviously) so he is talking to the mayor today



"Michael J. Kasper"
<mjkasper60@vzw.blackberry.net>

09/18/2007 10:25 AM

To "Jenny Burden" <jburden@hinshawlaw.com>

cc

bcc

Subject Fw: Fwd: FW: Mayor meeting

Please print
Sent from my Verizon Wireless BlackBerry

-----Original Message-----

From: Steve Trombley <stevetrombley@yahoo.com>

Date: Tue, 18 Sep 2007 08:08:44

To: mjkasper60@aol.com

Subject: Fwd: FW: Mayor meeting

--- "Trombley, Steve" <Stevet@ppca.org> wrote:

> Subject: FW: Mayor meeting
> Date: Tue, 18 Sep 2007 09:28:36 -0500
> From: "Trombley, Steve" <Stevet@ppca.org>
> To: <stevetrombley@yahoo.com>

>
>
>
>
>
>
>
>

> From: Knaub, Sara
> Sent: Tuesday, March 06, 2007 1:58 PM
> To: Fischman, Tracy; Novak, Becky; Huyck, Teri;
> Trombley, Steve
> Subject: Mayor meeting

>
>
>
> In one of our last meetings someone mentioned
> meeting with the Mayor of
> Aurora. I assume that you put materials together
> for that meeting and I
> was wondering if I could get copies of them. They
> would probably be
> helpful for me in the near future. Thanks much.

>
>
>
> sara

>
>
>
> Sara Knaub

> Director of Communications

> Planned Parenthood/Chicago Area

>
> 18 S. Michigan Ave., 6th Fl.

>
> Chicago, IL 60603
>
> 312.592.6842 (office)
>
> 773.485.2410 (cell)
>
> sarak@ppca.org
>
>
>
>
>
>
>
>
>

> NOTE: Confidential Information - This transmission
> and any files, which may accompany the transmission,
> contain information belonging to Planned
> Parenthood/Chicago Area which is confidential and/or
> legally privileged. The information is intended only
> for the use of the individual or entity named above.
> If you are not the intended recipient, you are
> hereby notified that any disclosure, copying,
> distribution or the taking of any action in reliance
> on the contents of this information is strictly
> prohibited and illegal. If you have received this
> transmission in error, please immediately notify us
> by telephone at (312) 592-6815 to arrange for the
> return of the transmission and any accompanying
> files.
>

Luggage? GPS? Comic books?
Check out fitting gifts for grads at Yahoo! Search
http://search.yahoo.com/search?fr=oni_on_mail&p=graduation+gifts&cs=bz



Call Detail (Continued)

User Name: PLANNED PARENHOOD/CHICAGO AREA

Rate Code: UNW9=Unlimited N&W, RM25=2500 Rollover Mins, ESM1=Unlimited Expd M2M

Rate Period (PD): NW=Nwkd, DT=Daytime

Feature: M2MC=EXPANDED M2M, CW=Call Waiting, VM=Voice Mail

Item	Day	Date	Time	Number Called	Call To	Mln	Rate Code	Rate Pd	Fea- ture	Airtime Charge	LD/Add'l Charge	Total Charge
272		02/21	8:22PM		CALIFAR	15	RM25	DT	CW			0.00
273		02/21	8:31PM		MAIL CL		RM25	DT	VM			0.00
274		02/21	8:34PM		CHICAG IL	2	RM25	DT				0.00
275		02/21	8:55PM		INGOMI CL		RM25	DT				0.00
276	WED	02/21	8:46AM		WASHIN DC	1	RM25	DT				0.00
277		02/21	8:49AM		INCOMI CL	15	RM25	DT				0.00
278		02/21	9:47AM		INCOMI CL	1	RM25	DT				0.00
279		02/21	9:53AM		CHICAG IL	2	RM25	DT				0.00
280		02/21	9:55AM	630-844-3827	AURORA IL	1	RM25	DT				0.00
281		02/21	9:57AM		WASHIN DC	2	RM25	DT				0.00
282		02/21	10:00AM	630-802-8811	INCOMI CL	1	RM25	DT				0.00
283		02/21	10:05AM		CHICAG IL	1	RM25	DT				0.00
284		02/21	10:06AM		CHICAG IL	2	RM25	DT				0.00
285		02/21	10:08AM		INGOMI CL		RM25	DT				0.00
286		02/21	10:08AM		INGOMI CL		RM25	DT				0.00
287		02/21	1:46PM		VMAIL CL	1	RM25	DT				0.00
288		02/21	2:59PM		VMAIL CL	1	RM25	DT				0.00
289		02/21	3:08PM		W PALM FL	19	RM25	DT				0.00
290		02/21	5:09PM		INCOMI CL	4	RM25	DT				0.00
291		02/21	7:24PM		HIGHLA IL	5	RM25	DT				0.00
292		02/22	6:39AM		WASHIN DC	2	RM25	DT				0.00
293		02/22	6:55AM		INCOMI CL	2	RM25	DT				0.00
294		02/22	7:07AM		VMAIL CL	1	RM25	DT	VM			0.00
295		02/22	7:22AM		CHICAG IL	1	RM25	DT				0.00
296		02/22	11:26AM		CHICAG IL	1	RM25	DT				0.00
297		02/22	11:30AM		CHICAG IL	1	RM25	DT				0.00
298		02/22	11:31AM		WASHIN DC	1	RM25	DT				0.00
299		02/22	11:35AM		CHICAG IL	3	RM25	DT				0.00
300		02/22	11:42AM		HIGHLA IL	1	RM25	DT				0.00
301		02/22	1:24AM		CHICAG IL	1	RM25	DT				0.00
302		02/22	1:27AM		CHICAG IL	1	RM25	DT				0.00
303		02/22	5:00PM		VMAIL CL	1	RM25	DT	VM			0.00
304		02/22	5:50PM		CHICAG IL	1	RM25	DT				0.00
305		02/22	5:50PM		CHICAG IL	1	RM25	DT				0.00
306		02/22	5:11PM		CHICAG IL	9	RM25	DT				0.00
307		02/22	5:21PM		CHICAG IL	1	RM25	DT				0.00
308		02/22	5:24PM		INCOMI CL	7	RM25	DT				0.00
309	FRI	02/23	8:38AM		VMAIL CL	1	RM25	DT	VM			0.00
310		02/23	8:39AM		NORTHB IL	2	ESM1	DT	M2MC			0.00
311		02/23	8:41AM		BELLWO IL	1	RM25	DT				0.00
312		02/23	8:41AM		BELLWO IL	1	RM25	DT				0.00
313		02/23	8:41AM		BELLWO IL	1	RM25	DT				0.00
314		02/23	8:41AM		BELLWO IL	1	RM25	DT				0.00
315		02/23	9:05AM		INCOMI CL	1	RM25	DT				0.00
316		02/23	9:06AM		CHICAG IL	1	RM25	DT				0.00
317		02/23	9:07AM		CHICAG IL	1	RM25	DT				0.00
318		02/23	9:16AM		CHICAG IL	1	RM25	DT				0.00
319		02/23	9:16AM		VMAIL CL	1	RM25	DT	VM			0.00
320		02/23	9:18AM		BELLWO IL	4	RM25	DT				0.00
321		02/23	1:26PM		WASHIN DC	1	RM25	DT	VM			0.00
322		02/23	1:26PM		CHICAG IL	1	RM25	DT				0.00
323		02/23	1:30PM		INCOMI CL	1	RM25	DT				0.00
324		02/23	1:30PM		INCOMI CL	1	RM25	DT				0.00
325		02/23	1:30PM		CHICAG IL	1	RM25	DT				0.00

EXHIBIT 3



FRIDAY, APRIL 20, 2007
CITY OF CHICAGO
DEPARTMENT OF
PROCUREMENT SERVICES

Sealed Bids/Proposals will be received by the City of Chicago, on the date and time, (Chicago Time), stated for those specific Bids/Proposals listed below, in Room 301, City Hall, 121 North LaSalle Street, Chicago, Illinois at which time and place, Bids/Proposals will be opened and publicly read aloud for the following:

DESCRIPTION: E45 AND DIESEL SPORT UTILITY VEHICLES
SPECIFICATION NO.: 55349
REQ. NUMBER: 2497
PRE-BID/PROPOSAL CONFERENCE: NON-MANDATORY
DATE: TUESDAY, MAY 1, 2007
TIME: 9:30 A.M.
LOCATION: CITY OF CHICAGO
DEPARTMENT OF PROCUREMENT SERVICES
BID & BOND ROOM, ROOM 301, CITY HALL
121 NORTH LASALLE STREET
CHICAGO, ILLINOIS 60602
BID/PROPOSAL OPENING DATE: TUESDAY, MAY 15, 2007
TIME: 11:00 A.M.
CONTACT: Ahmad N. Nayamuh Phone: 312-744-9761
 Email: anayamuh@cityofchicago.org

Bids/Proposals, requiring a Bids/Proposals deposit, must be accompanied by a bid bond provided by a surety company authorized to do business in the State of Illinois or the equivalent in the form of a cashier's check or money order, in the amount stated, drawn on a responsible bank or financial institution doing business in the United States, and made payable to the City of Chicago. Cash, non-certified checks or promissory certificates, are not acceptable forms of Bids/Proposals deposits.

Any Bids/Proposals submitted, which are not properly signed, or accompanied by an acceptable form of deposit, will be considered non-responsive, and the bid will be disqualified from consideration. Any late Bids/Proposals received after announced date and time, for the opening of Bids/Proposals, will not be accepted.

Bids/Proposals must be submitted on documents provided by the City of Chicago, which are available in the Department of Procurement Services, Bid and Bond Room, Room 301, City Hall, Chicago, Illinois 312-744-9773.

Where applicable, copies of specifications, plans, and drawings may be obtained by placing a deposit in the amount specified above, for each set of documents. The City will only accept certified checks, cashier's checks, or money orders. The plan deposit will be refunded upon the return of said documents, in good condition, within ten (10) calendar days after the bid opening date. Failure to return said documents within the period stated above, will result in the Bidders/Proposers forfeiting the plan deposit.

The above Bids/Proposals estimated range, is intended to represent the size of the project, or anticipated usage.

The Chief Procurement Officer, reserves the right to reject any or all Bids/Proposals if deemed in the best interest of the City of Chicago.

RICHARD M. DALEY **BARBARA A. LUMPKIN**
MAYOR **CHIEF PROCUREMENT OFFICER**

A COMPLETE LIST OF BID OPENINGS CAN BE FOUND ON THE INTERNET
<http://www.cityofchicago.org/purchasing/>

FIND IT • BUY IT • FIX IT • RENT IT • SELL IT
 Just Turn to Today's Classifieds in the
Chicago Sun-Times

The above notice of public hearing is required by Section 1470 of the Internal Revenue Code of 1986, as amended. At the time and place set for the public hearing, residents, taxpayers and other interested persons will be given the opportunity to express their views for or against the proposed project and the Bonds. Written comments may also be submitted to the Interim Executive Director of the Authority at her office located at 180 North Station Avenue, Suite 2555, Chicago, Illinois 60601, until May 4, 2007.

In accordance with the Americans with Disabilities Act ("ADA"), if any person with a disability as defined by the ADA needs special accommodations to participate in the public hearing, then not later than May 3, 2007, he or she should contact the Authority at (312) 651-1300.

Dated: April 20, 2007

/s/ Jill Bendiana
 Interim Executive Director
 Illinois Finance Authority

CHA 2007 SUMMER FOOD PROGRAM

Invitation for Bid No. 01509

CHA invites Food Management Companies to Submit Bids to Prepare and deliver breakfast meals and cold and hot lunches to approximately 143 sites within the City of Chicago for the Summer Food Program that feeds children during the summer.

Time Period: June 18, 2007 through August 31, 2007, including a special event on or about September 1, 2007.

Delivery must be made in a timely fashion in order to ensure meal service at the properly approved times.

Estimated Quantities: This program will serve approximately 2,000 breakfast meals and 16,000 lunches per day at approximately 143 different sites.

Bid Security Required: 5% of the bid. If awarded a Contract, the Contractor must furnish a Performance Bond, in the amount of 10% of the estimated value of the contract. The surety company must appear on the U.S. Treasury Circular No. 570 published annually in the Federal Register.

All questions should be submitted in writing and faxed to Sandra Freeman at 312-953-5855 or E-mailed to streaman@chicago.gov no later than Friday, April 27, 2007 at 12:00 p.m. Local Time.

BID DUE DATE/BIDS TO BE OPENED MONDAY, MAY 7, 2007 AT 10:00 A.M. LOCAL TIME

60 E. VAN BUREN, CHICAGO, IL 131TH FLOOR

This contract shall be subject to the applicable compliance standards and procedures of Executive Order No. 11246, as amended, Equal Opportunity, and other provisions as specifically set forth in the specifications.

All contracts issued as result of this solicitation are subject to review by the Illinois State Board of Education, Division of Financial Outreach, and Nutrition Program with the State of Illinois. In accordance with Federal law and United States Department of Agriculture (USDA) policy, this institution is prohibited from discriminating on the basis of race, color, national origin, sex, age, or disability, to the a complaint of discrimination, write USA, Director, Office of Civil Rights, 1400 Independence Avenue, SW, Washington, D.C. 20250-5410 or call 800/795-5272 or 202/770-6539 (voice). USDA is an equal opportunity provider and employer.

Note: Program guidelines stipulate the Food Service Management Company must agree to provide accurate and final billing for services to the organization within thirty (30) days following the end of the dining period.

Invitation for Bid Number 01509 and further information may be obtained by contacting Sandra Burson-Freeman at (312) 913-5854

"Best" approval of Section 1470 of the Internal Revenue Code of 1986. At the time and place set forth above, all interested parties may appear and be heard. Written comments may also be submitted to the Interim Executive Director of the Illinois Authority at her office located at Two Prudential Plaza, 180 North Station Avenue, Suite 2555, Chicago, Illinois 60601, until May 3, 2007. After the public hearing the Governor of the State of Illinois will consider approval of the issuance of the Bonds by the Colorado Authority ("ADA").

In accordance with the Americans with Disabilities Act ("ADA"), if any person with a disability as defined by the ADA needs special accommodations to participate in the public hearing, then not later than May 3, 2007, he or she should contact the Illinois Authority at (312) 651-1300.

Notice Dated: April 20, 2007

/s/ Jill Bendiana
 Interim Executive Director
 Illinois Finance Authority

Notice of Public Hearing

Public notice is hereby given that on May 4, 2007, at 9:00 A.M., in the offices of the Illinois Finance Authority, ("Authority") at 427 East Monroe Street, Suite 202, Springfield, Illinois 62701, a public hearing will be held before the Interim Executive Director of the Authority, or her designee, regarding the proposed issuance by the Authority of variable rate demand revenue bonds as hereinafter described (the "Bonds"). The proceeds of the Bonds will be loaned to Planned Parenthood/Chicago Area, an Illinois not for profit corporation (the "Corporation") and Gemini Office Development LLC, an Illinois limited liability company affiliated with the Corporation ("Gemini"). The Bonds will be issued in an aggregate principal amount not to exceed \$14,000,000 and the proceeds thereof will be used, together with other available funds: (i) to pay and reimburse Gemini for acquiring, constructing, installing and equipping a healthcare center located at 240 N. Oakhurst Drive, Aurora, Illinois 60504; (ii) to refinance costs of renovating, constructing, installing and equipping certain health centers of the Corporation located at 5927 W. Chicago Avenue, Chicago, Illinois 60651 and 11250-11258 South Halsted Street, Chicago, Illinois 60628; (iii) for other capital costs of the Corporation for use in its Chicago and suburban facilities located at the above referenced locations as well as at Chicago and suburban facilities located at 1314 North Roselle Road, Schaumburg, Illinois 60195; 1507 North Aurora Road, Westmont, Illinois 60553; 11522 North Milwaukee Avenue, Chicago, Illinois 60622; 6353 North Broadway, Chicago, Illinois 60660; 1200 North LaSalle Street, Chicago, Illinois 60610; 6059 South Ashland Avenue, Chicago, Illinois 60638 (collectively with (i) and (ii), the "Project"); (iv) pay interest with respect to certain portions of the Project; and (v) pay certain costs of issuance relating to the Bonds.

The Bonds do not constitute a debt of the Authority or the State of Illinois within the meaning of any provisions of the Constitution or statutes of the State of Illinois or a pledge of the full faith and credit of the Authority or the State of Illinois or grant to the owners thereof any right to have the Authority or the General Assembly levy any taxes or appropriate funds for the payment of the principal or interest thereon. The Bonds will be payable solely out of the revenues and other funds pledged for their payment by the Corporation.

The above notice of public hearing is required by 1470 of the Internal Revenue Code of 1986, as amended. All the public hearing, residents, taxpayers and other interested persons will have the opportunity to express their views for or against the Project and the Bonds. Written comments may also be submitted to the Authority at its office located at 180 North Station Avenue, Suite 2555, Chicago, Illinois 60601-6701, until May 3, 2007.

In accordance with the Americans with Disabilities Act ("ADA"), if any person with a disability as defined by the ADA needs special accommodations to participate in the public hearing, then not later than May 4, 2007, he or she should contact the Authority at (312) 651-1300.

Dated: April 20, 2007

/s/ Jill Bendiana
 Interim Executive Director
 Illinois Finance Authority

Let us take you from rubber heels to rubber wheels. Find your automobile in the Classifieds in the Chicago Sun-Times 312-321-2345

NORTHEAST ILLINOIS REGIONAL COMMERCE RAILROAD CORPORATION
RAILROAD CORPORATION
D/B/A METRA
INVITATION FOR BID

SEALED BIDS will be received by the Northeast Illinois Regional Commerce Railroad Corporation (D/B/A METRA) at its offices, 547 West Jackson Boulevard, 17th Floor, Chicago, Illinois, 60601, until 2:00 P.M. on the day(s) indicated below. At that time, all such bids received will be publicly read aloud for the purpose of purchasing the following:

DESCRIPTION: Safety Award Lunchrooms for Field Personnel

IFB NO.: 82436
OPENING DATE: 5/8/07

All Bids must be only in the form prescribed by METRA and must be made in accordance with this Invitation for Bid and other Contract documents, all of which are on file and available for examination at the office of METRA at the above address and are made part of this notice as though fully set forth herein. Copies of such documents can be obtained from such office on written request to METRA, Material Management Department. Requests for any change in the Contract documents must be received in writing by METRA no later than ten (10) calendar days prior to the date for Bid opening. METRA reserves the right to accept any Bid or any part thereof or to reject any and all Bids.

METRA in accordance with Title VI of the Civil Rights Act of 1964, hereby notifies all bidders that it will affirmatively ensure that in regard to any Contract entered into pursuant to this invitation minority business enterprises will be afforded full opportunity to submit bids in response to this invitation and will not be discriminated against on the grounds of race, color, creed or national origin in consideration for an award.

The Invitation for Bid contains specific requirements concerning DBE documents which must be submitted at the designated time.

Sh. Buyer: Loui Lee
Ziggy

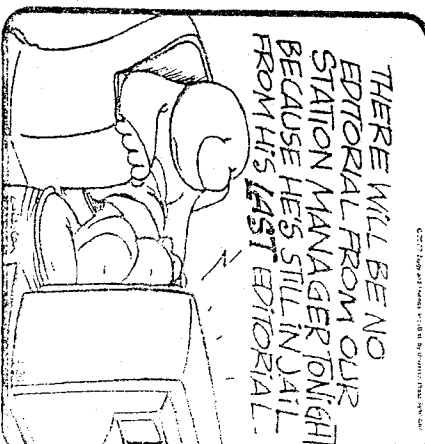
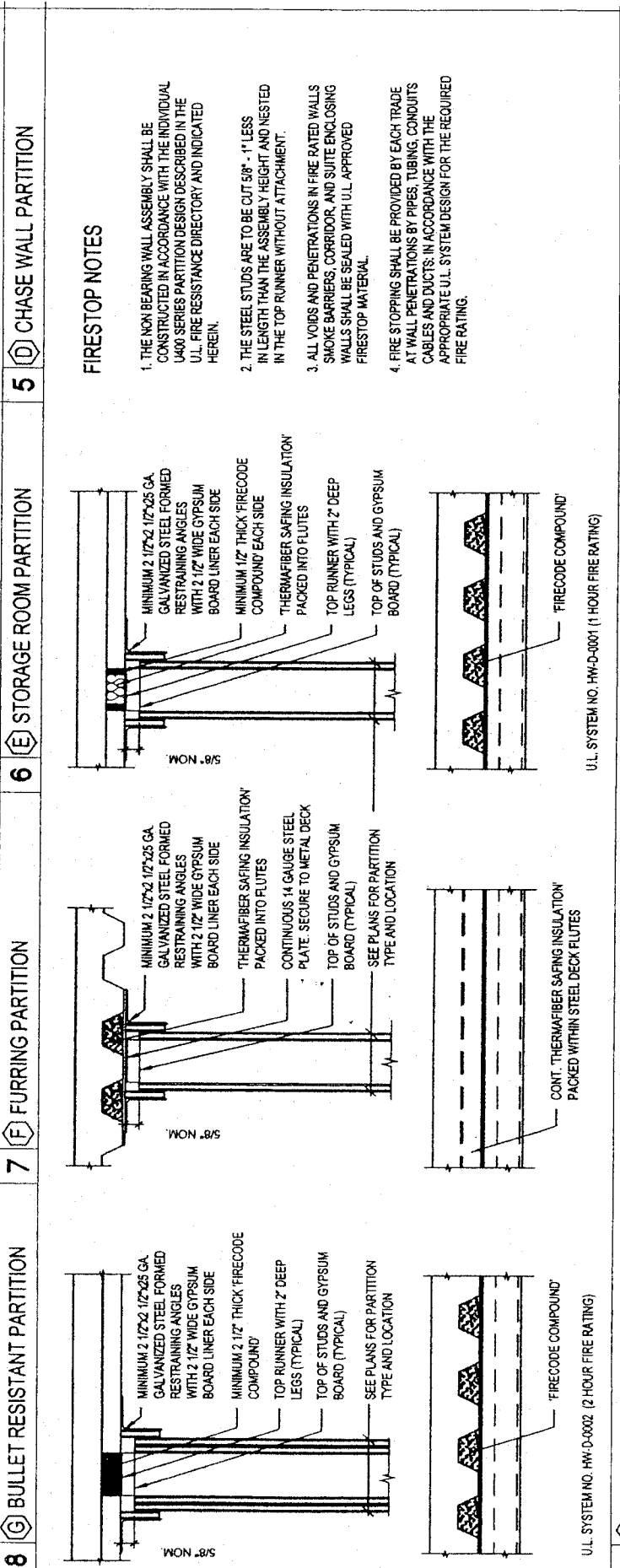
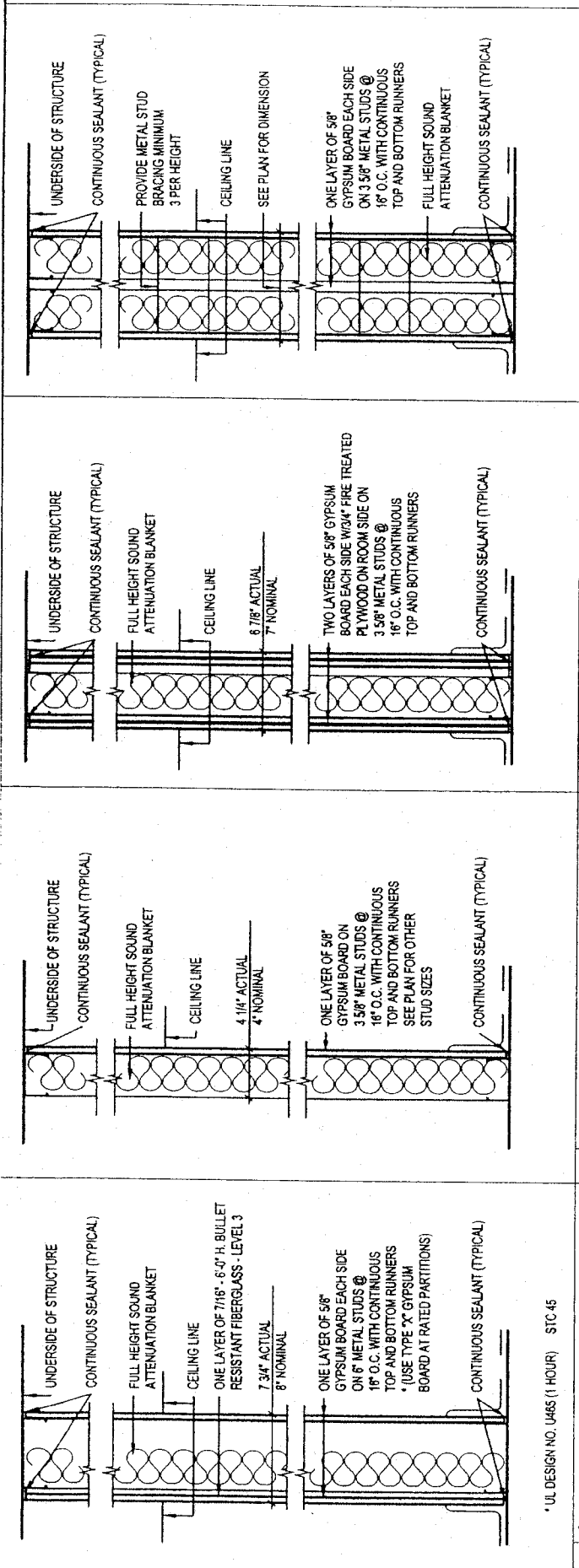

EXHIBIT 4



16 (O) FIRESTOP NOTES AND DETAILS @ FLUTED DECK AND PENETRATIONS

FIRESTOP NOTES

1. THE NON BEARING WALL ASSEMBLY SHALL BE CONSTRUCTED IN ACCORDANCE WITH THE INDIVIDUAL U400 SERIES PARTITION DESIGN DESCRIBED IN THE U.L. FIRE RESISTANCE DIRECTORY AND INDICATED HEREIN.
2. THE STEEL STUDS ARE TO BE CUT 5/8" - 1" LESS IN LENGTH THAN THE ASSEMBLY HEIGHT AND NESTED IN THE TOP RUNNER WITHOUT ATTACHMENT.
3. ALL VOIDS AND PENETRATIONS IN FIRE RATED WALLS SMOKE BARRIERS, CORRIDOR, AND SUITE ENCLOSING WALLS SHALL BE SEALED WITH U.L. APPROVED FIRESTOP MATERIAL.
4. FIRE STOPPING SHALL BE PROVIDED BY EACH TRADE AT WALL PENETRATIONS BY PIPES, TUBING, CONDUITS CABLES AND DUCTS; IN ACCORDANCE WITH THE APPROPRIATE U.L. SYSTEM DESIGN FOR THE REQUIRED FIRE RATING.

U.L. SYSTEM NO. HW-D-0001 (1 HOUR FIRE RATING)

U.L. SYSTEM NO. HW-D-0002 (2 HOUR FIRE RATING)

A9.D



JENSEN & HALSTEAD LT
 ARCHITECTURAL CORPORATION
 110 West Ontario Street
 Chicago, Illinois 60601
 312.664.7377 FAX
 312.664.7338 TEL

DOOR AND FRAME NOTES

1. ALL DOOR SHALL BE 2 1/4" MIN. 1 1/2" MAX.
2. ALL DOOR SHALL BE 2 1/4" MIN. 1 1/2" MAX.
3. ALL DOOR SHALL BE 2 1/4" MIN. 1 1/2" MAX.
4. ALL DOOR SHALL BE 2 1/4" MIN. 1 1/2" MAX.
5. ALL DOOR SHALL BE 2 1/4" MIN. 1 1/2" MAX.
6. ALL DOOR SHALL BE 2 1/4" MIN. 1 1/2" MAX.
7. ALL DOOR SHALL BE 2 1/4" MIN. 1 1/2" MAX.
8. ALL DOOR SHALL BE 2 1/4" MIN. 1 1/2" MAX.
9. ALL DOOR SHALL BE 2 1/4" MIN. 1 1/2" MAX.
10. ALL DOOR SHALL BE 2 1/4" MIN. 1 1/2" MAX.

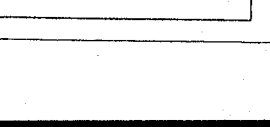
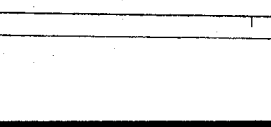
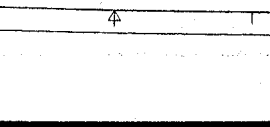
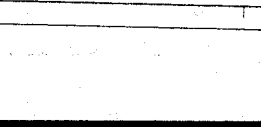
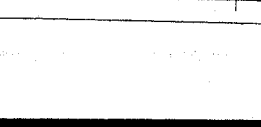
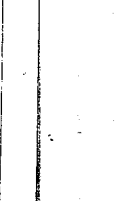
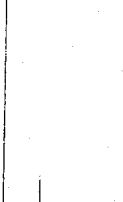
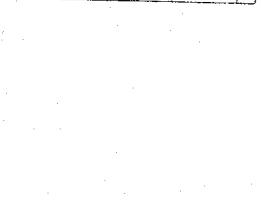
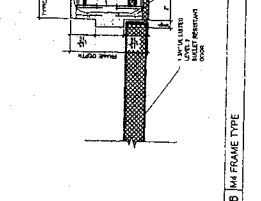
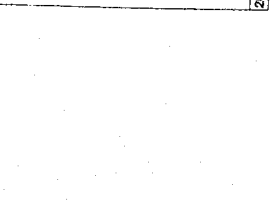
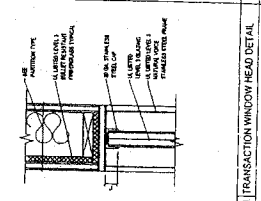
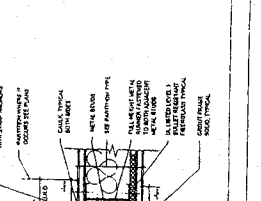
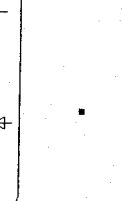
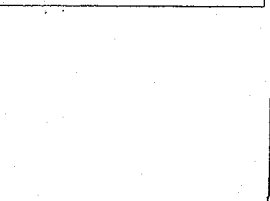
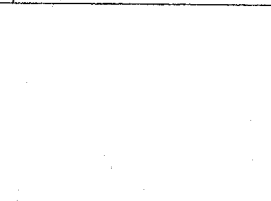
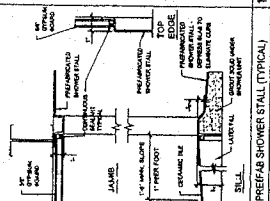
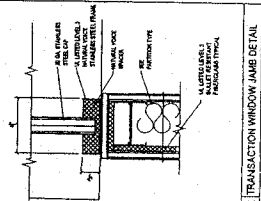
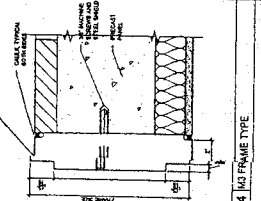
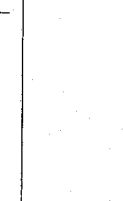
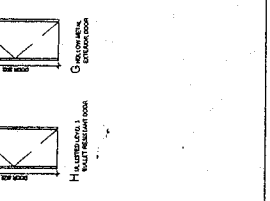
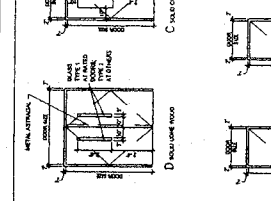
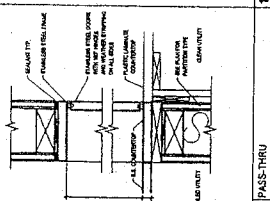
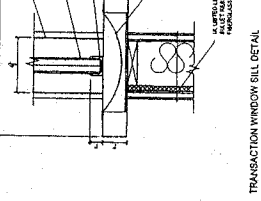
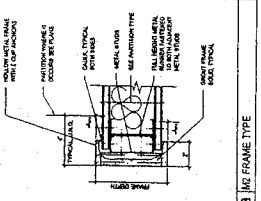
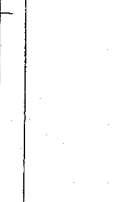
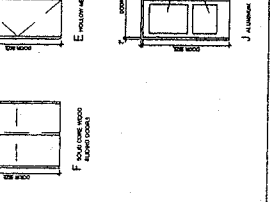
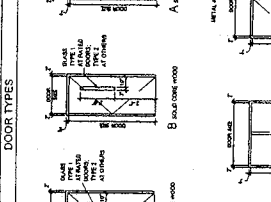
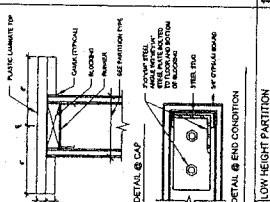
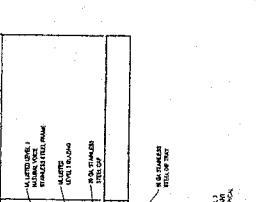
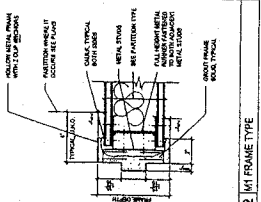
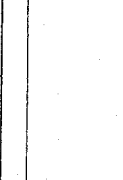
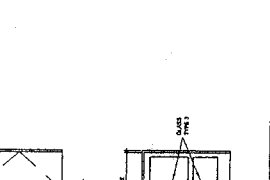
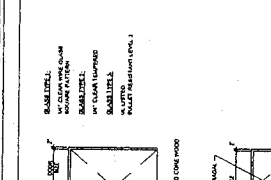
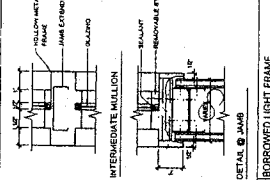
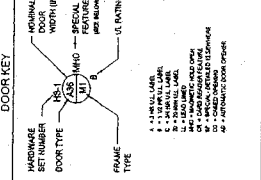

Revisions	Project	GEMINI OUTPATIENT FACILITY
No.	Date	Description
1	02.14.07	ISSUED FOR CONSTRUCTION

Sheet Title: **FRAME TYPES AND DETAILS**

Project: GEMINI OUTPATIENT FACILITY

Client: GEMINI OFFICE DEVELOPMENT
 DANBURST DRIVE
 ORLAND, ILLINOIS

Scale: 1/8" = 1'-0"

Sheet Number: **A9.1**

Drawn by: G
 Checked by: G
 Approved by: G

<p>DOOR AND FRAME NOTES</p> <ol style="list-style-type: none"> 1. ALL DOORS SHALL BE 7'7" HIGH, 1 3/4" THICK UNLESS OTHERWISE NOTED 2. ALL LABELED DOORS SHALL BE COVERED BY U.L. REQUIREMENTS AND SHALL BEAR PHYSICAL U.L. LABEL OF FRAME RATING SPECIFIED 3. VERIFY ALL PARTITION THICKNESS PRIOR TO DETERMINING FRAME THROAT SIZE 4. ALL DOOR FRAME THROAT SIZE DIMENSIONS SHALL BE 1/16" GREATER ON EACH SIDE OF PARTITION 5. DOUBLE DOORS SHALL HAVE METAL ASTRAGAL 	<p>DOOR KEY</p>	<p>INTERMEDIATE MULLION</p> <p>DETAIL @ JAMB</p>
<p>2 M1 FRAME TYPE</p>	<p>3 M2 FRAME TYPE</p>	<p>18 LOW HEIGHT PARTITION</p> <p>DETAIL @ CAP</p> <p>DETAIL @ END CONDITION</p>
<p>4 M3 FRAME TYPE</p>	<p>6 M4 FRAME TYPE</p>	<p>11 TRANSACTION WINDOW SILL DETAIL</p>
<p>4 M3 FRAME TYPE</p>	<p>12 TRANSACTION WINDOW JAMB DETAIL</p>	<p>13 TRANSACTION WINDOW HEAD DETAIL</p>
<p>6 M4 FRAME TYPE</p>	<p>13 TRANSACTION WINDOW HEAD DETAIL</p>	<p>20 PREFAB SHOWER STALL (TYPICAL)</p>

DOOR TYPES

- GLASS TYPE 1- 1/4" CLEAR WIRE GLASS SQUARE PATTERN
- GLASS TYPE 2- 1/4" CLEAR TEMPERED
- GLASS TYPE 3- UL LISTED BULLET RESISTANT LEVEL 3

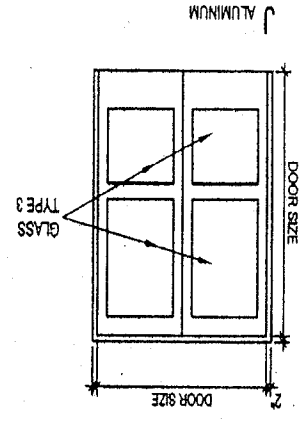
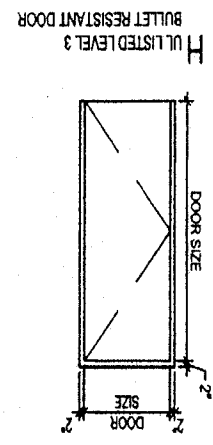
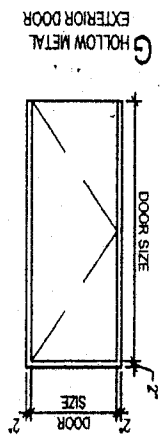
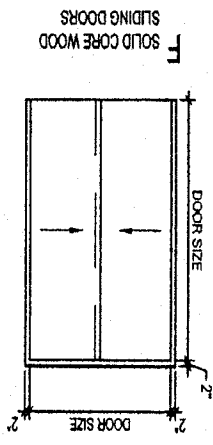
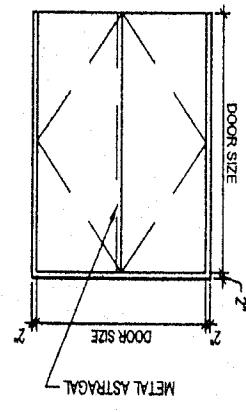
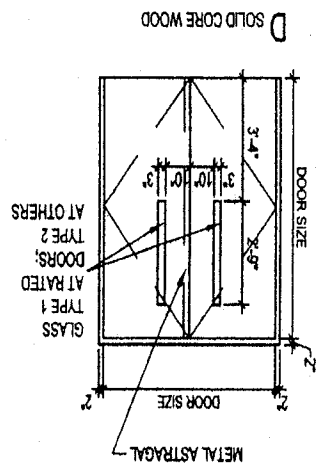
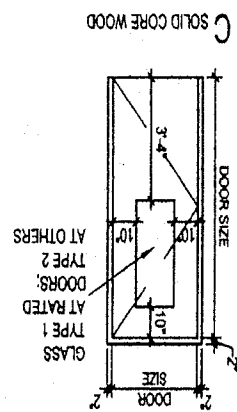
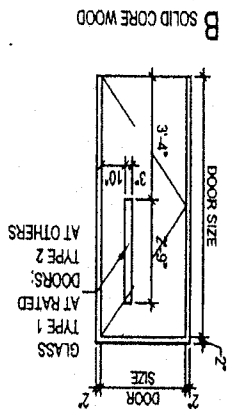
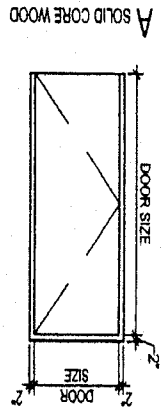



JENSEN & HALSTEAD

A HISTORY OF INNOVATION IN ARCHITECTURE

ARCHITECTURAL CORPORATION
1000 North 10th Street
Billings, Montana 59102
406.243.1111
406.243.1112

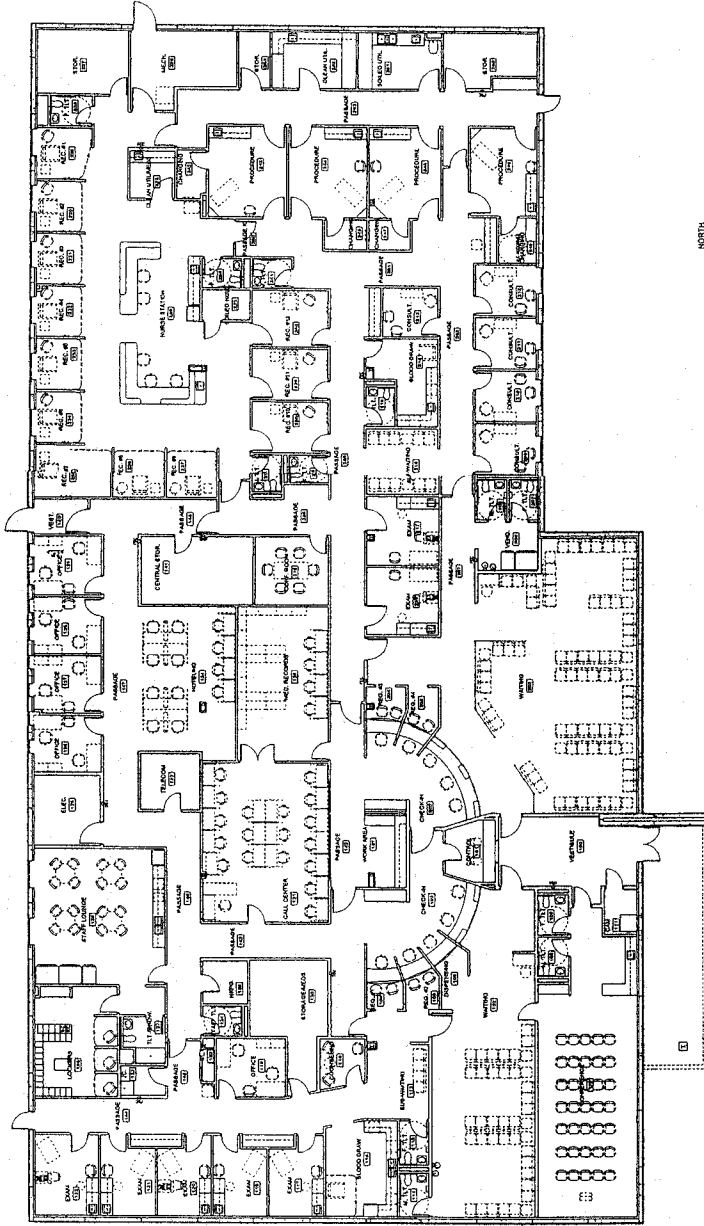

1 FURNITURE PLAN
PAGE 04 OF 110

No.	Date	Description
1	01.15.11	ISSUED FOR CONSTRUCTION

PROJECT: GEMINI OUTPATIENT FACILITY

CLIENT: GEMINI OFFICE DEVELOPMENT
1000 NORTH 10TH STREET
BILLINGS, MONTANA 59102

PROJECT TITLE: INTERIOR FURNITURE PLAN

DATE: 01.15.11
DRAWN BY: JH
CHECKED BY: JH
APPROVED BY: JH
SHEET NUMBER: 13.1
SCALE: 1/8" = 1'-0"

EXHIBIT 5

[Back to regular view](#) [Print this page](#)

Aurora reviewing clinic approval

City hires law firm to check Planned Parenthood application process

August 28, 2007

By **ANDRE SALLES** Staff Writer

AURORA -- Responding to the controversy surrounding a new Planned Parenthood clinic, the city of Aurora has hired a law firm to review its approval process for the far East Side business to make sure there was no wrongdoing.

Mayor Tom Weisner's chief of staff, Bill Wiet, said in a memo Monday that the city has hired Chicago attorney Richard Martens to examine the city's development process, which culminated in approval in November 2006. Martens is past chairman of the Chicago Bar Association Local Government Committee and serves on a committee for the Illinois Municipal League.

"This is definitely a rare occurrence," said city spokesman Carie Anne Ergo. "I don't know of another instance in which the city has done this."

Why this time? Ergo said there have been questions raised in recent weeks about whether Planned Parenthood might have taken an inappropriate tack by bringing the development in under the Gemini Development Corp. moniker. Though the development was approved in November, its specific use was only revealed last month, sparking outrage from anti-abortion groups.

The city granted Planned Parenthood a 30-day temporary occupancy permit, which expires Sept. 17, prior to the center opening. Ergo said the goal is to have Martens' review completed by the following day, when the city will be asked to issue a permanent occupancy permit.

"If the review indicates that our laws have been followed, the city will be obligated to issue a final occupancy permit for the facility opening on Sept. 18, 2007," Wiet wrote in his memo.

Planned Parenthood/Chicago Area representatives could not be reached for comment Monday night.

News of the independent review pleased Eric Scheidler, communications director for the Chicago-based Pro-Life Action League. Scheidler's group has been picketing and protesting the new clinic since hearing about it, and he said he thinks Planned Parenthood deceived the city.

"I don't have the disadvantage of being a lawyer," he said. "I'm just a guy who thinks that if you lie to government officials, you ought to be held accountable."

Scheidler said he is glad to see the city "stepping up," and sees this move as a potential first step toward refusing to issue an occupancy permit, and opening the door to future litigation.

The Pro-Life Action League last week filed suit against the city, alleging that Aurora police compromised their free speech by giving conflicting information about where protesters could stand, or how they could display signs.

But Bonnie Grabenhofer, president of the Illinois chapter of the National Organization for Women, said she is outraged that the anti-abortion groups are "trying to intimidate the city." She said Aurora has been fair throughout the process, and she understands the city's desire to prove they did nothing wrong.

"Planned Parenthood did everything they were required to do," she said. "The city of Aurora did everything they were required to do. Hiring a lawyer to investigate that seems like a

waste of taxpayer money."

Both sides of the debate plan to speak at tonight's 6 p.m. City Council meeting. According to City Clerk Cheryl Vonhoff, more than 60 people have signed up to address the council on this issue.

Ergo said Martens has been placed on retainer, and the city has no estimate of how much his services will cost. But the savings in allaying future litigation could make it all worth it.

"We believe we have followed the letter of the law, and we're just taking additional steps to make sure that's the case," she said. "It's just a case of us crossing the Ts and dotting the Is."

EXHIBIT 6

[Back to regular view](#) [Print this page](#)

Objections raised to choice of law firm planned parenthood process

September 1, 2007

By **ANDRE SALLES** Staff Writer

AURORA -- In response to objections from several aldermen, Mayor Tom Weisner has decided to allow the City Council to choose a new attorney to review the approval process for a controversial Planned Parenthood clinic on the far East Side.

The facility was approved in November 2006 by the Planning and Development Committee, and because the property on East New York Street was already zoned for a medical building, a sign-off by the full council was not required.

But questions have been raised in recent weeks over whether Planned Parenthood acted appropriately during the process. The development was approved under the name Gemini Office Development, and the true occupant of the building was not revealed until recently.

The clinic has been causing a stir in the community because it will provide abortions.

Earlier this week, the city hired Chicago lawyer Richard Martens to do a review of the approval process, hoping to have his report in hand by Sept. 17, when Planned Parenthood's temporary occupancy permit expires. But after asking for and receiving objections to Martens' hiring, Weisner has decided to leave it in the hands of the council.

Objections were filed by Aldermen Stephanie Kifowit, 3rd Ward; Rick Lawrence, 4th Ward; Chris Beykirch, 8th Ward; and Richard Irvin, at-large. The four are concerned that Martens rents office space at 20 N. Wacker Drive in Chicago from the city's outside legal counsel, Klein, Thorpe and Jenkins. Martens also worked as a summer legal clerk for the firm in 1968 and 1971.

City spokesman Carie Anne Ergo said the only criteria for selecting the independent reviewer was that he not have previously contracted with the city, or been linked with Planned Parenthood or anti-abortion organizations.

"Where he rents his office from is immaterial," Ergo said. "It's not a concern for the mayor."

But it is a concern for some aldermen, and the mayor has left it in the council's hands. He's tasked the two attorneys on the council, Irvin and Bob O'Connor, to select a suitable candidate -- which could include Martens, if they chose -- and gain consensus from the rest of the council.

O'Connor, however, is concerned there will not be enough time. The deadline set forth in Weisner's memo for the final report is Sept. 12, six days before a permanent occupancy permit would need to be issued to meet the original timeline. City officials estimate the investigation would take a week to complete, leaving the council only a couple of days next week to find a new independent attorney they can agree on.

"We can't be locked into that because it's not within our control," O'Connor said. "We'll be dealing with (attorneys who) have their own worlds, their own timing. I'm not positive we can say we can fit it into that time period."

Aldermen could extend the temporary occupancy permit to meet the needs of a longer investigation.

Ergo said the investigation needs to be done by the original deadline to "protect the taxpayers of Aurora against a potentially costly lawsuit" filed by Planned Parenthood.

"If the City Council is unable to reach a decision, the mayor is ready to step in and choose

an independent attorney," she said.

As for Martens, who has already substantially completed his investigation at \$185 an hour, he took the news in stride.

"The city needs to do whatever it feels comfortable with," he said. "Whatever works for the city works for me."

EXHIBIT 7

[Back to regular view](#) [Print this page](#)

New lawyer chosen to review Planned Parenthood application

September 8, 2007

By **ANDRE SALLES** Staff Writer

AURORA – Aldermen have selected a new attorney to conduct an investigation into Planned Parenthood's entry into Aurora.

The choice is Phillip A. Luetkehans, of the Itasca-based firm Schirott and Luetkehans. That firm has an extensive list of municipal clients over 36 years, including the cities of Geneva, St. Charles and Yorkville. Luetkehans is a resident of Wheaton, and formerly worked for the DuPage County state's attorney's office.

Luetkehans was selected by Aldermen-at-Large Bob O'Connor and Richard Irvin, the two attorneys on the City Council. Irvin said that both he and O'Connor received separate recommendations for Luetkehans over the last few days.

If approved by the full council, Luetkehans will begin next week looking into a development process that some have decried as deceptive. Planned Parenthood expects to open its new facility on East New York Street on Sept. 18, and has drawn controversy with its plans to perform abortions there.

The building was approved last year under the name Gemini Office Development, and the facility's true occupant was not revealed until recently. Some have charged that Planned Parenthood lied to aldermen to conceal its true identity. Under pressure from anti-abortion groups, the city agreed to an independent investigation last month.

The attorney that city staff selected, Chicago-based Richard Martens, was found to have connections with the city's outside legal counsel, Klein, Thorpe and Jenkins. Four aldermen objected, and Mayor Tom Weisner assigned O'Connor and Irvin to choose a replacement and gain consensus from the council.

In his memo to aldermen, O'Connor emphasized that Luetkehans has no connection with the city, its legal counsel, Planned Parenthood, or any anti-abortion or abortion rights groups. Aldermen have been asked to file any objections to Luetkehans' selection by Monday at noon.

"I don't see any objection," said Alderman Stephanie Kifowit, 3rd Ward. "I can't see why I would file anything."

Kifowit was one of the four who objected to Martens, along with Aldermen Rick Lawrence, 4th Ward; Chris Beykirch, 8th Ward; and Irvin. Beykirch agreed with Kifowit, saying that he "100 percent" supports the choice, and Lawrence said he is encouraged by what he saw in O'Connor's memo, but would continue to do his own research over the weekend.

Officials from Planned Parenthood said this week that they still plan to open on Sept. 18, although it is looking unlikely that the investigation will be completed by then. Weisner said Thursday that he would not issue an occupancy permit until the investigation is finished.

EXHIBIT 8

[Back to regular view](#) [Print this page](#)

Council choses Barsanti

County's top lawyer to review Planned Parenthood approval

September 19, 2007

By **ANDRE SALLES** Staff Writer

AURORA – Seemingly unable to find a suitable candidate to conduct an independent investigation into Planned Parenthood's approval process, the city of Aurora will turn to the highest legal authority in Kane County.

State's Attorney John Barsanti has agreed to review reports made by two other attorneys – Chicago-based Richard Martens and Itasca-based Phillip Luetkehans.

Both were chosen – first Martens, then Luetkehans – to conduct an independent review of the process by which Planned Parenthood received approval for its new 22,000-square-foot facility at East New York Street and Oakhurst Drive.

Some have charged that Planned Parenthood deceived the city by coming in under the name Gemini Office Development. Gemini received approval for the building in November, but the true occupant of the new facility was revealed only eight months later. City officials commissioned the independent review last month.

Four aldermen objected to the choice of Martens to conduct the review because of his connections with the city's outside legal counsel, Chicago-based Klein, Thorpe and Jenkins.

Aldermen Richard Irvin and Bob O'Connor then chose Luetkehans to replace Martens, but news broke last week that Luetkehans contributed to Irvin's failed mayoral campaign in 2005, raising doubts about his suitability for the job as well.

Aldermen discussed handing the matter over to Barsanti in an executive session Tuesday and, according to O'Connor, the idea met with unanimous approval.

"He's willing to step up and undertake the task, to his credit," O'Connor said. "We will certainly take advantage of it."

Barsanti will take up the review for free, officials said. Martens completed his report at a cost of \$185 per hour, and city officials could not be reached to confirm Luetkehans' fee.

Planned Parenthood officials could not be reached for comment, although Planned Parenthood/Chicago Area CEO Steve Trombley has described the investigation as "politicized."

A federal judge is expected to rule Thursday on Planned Parenthood's request for an emergency injunction to open its doors.

Aurora Mayor Tom Weisner has said the city will not issue a permanent occupancy permit until the investigation is complete. The clinic's temporary occupancy permit expired Monday.

No timeline has been set for Barsanti's review, though O'Connor said Barsanti is "aware of the need for efficiency in this matter."

EXHIBIT 9

-----Original Message-----

From: Melissa Ernst [mailto:melissa.l.ernst@gmail.com]
Sent: Wednesday, September 19, 2007 9:17 AM
To: Trombley, Steve
Subject: Fwd: Aurora Resident Asking you to Support Planned Parenthood

----- Forwarded message -----

From: Chris Beykirch <realtorchris@sbcglobal.net>
Date: Sep 18, 2007 9:28 AM
Subject: Re: Aurora Resident Asking you to Support Planned Parenthood
To: Melissa Ernst <melissa.l.ernst@gmail.com>
Cc: AldermanSchuler@aol.com, w2aldermangarza@yahoo.com,
skifowit@yahoo.com, ricklawrence@sbcglobal.net, wpeters@aurora-il.org,
smewmaw@aurora-il.org, shartburns@aurora-il.org,
AldermanKeith@aol.com, LDElmore@aol.com

Melissa-

Since you decided to make your e-mail widely public, I did too. I gave you a perspective on the issue that I felt you should know. I think PP and its leaders are widely deceptive to the governments of communities all around the U.S. I do not like the fact they took our ability to plan out of our hands with their deception. I can't imagine that even a pro-PP person could see that the long term effects of their location are not good for my neighborhood.

You touched on my morality. I have never been a Pro-Life activist, but I am Pro-Life. I do believe life begins at conception. Why else would people put ultrasounds on their refrigerator? Even though I am elected, I come to the office with life experiences that lead me one way or another. I am Pro-Life. I will also abide by the law of the land as I am sworn to do. I will not go along with it though until the law says I must. I will also never think positively about a "medical practice" that will perform abortions on minors without parental consent regardless of their extremist ideals of why they should be allowed to.

I hope you understand I am entitled to an opinion as much as you.

Chris Beykirch

----- Original Message -----

From: Melissa Ernst <melissa.l.ernst@gmail.com>
To: Chris Beykirch <realtorchris@sbcglobal.net>
Cc: AldermanSchuler@aol.com; w2aldermangarza@yahoo.com;
skifowit@yahoo.com; ricklawrence@sbcglobal.net; wpeters@aurora-il.org;
smewmaw@aurora-il.org; shartburns@aurora-il.org;
AldermanKeith@aol.com; LDElmore@aol.com
Sent: Monday, September 17, 2007 9:01:59 PM
Subject: Re: Aurora Resident Asking you to Support Planned Parenthood

